

Mars InSight Lander 1/24th Scale Model

Model design copyright 2019
Michael Mackowski
Model version D1.0

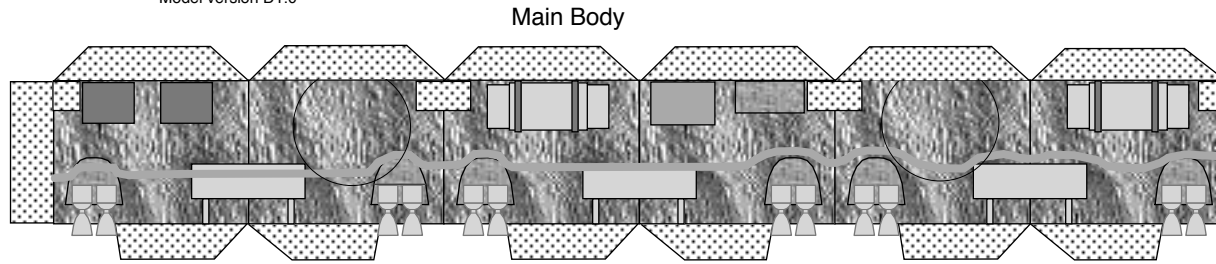

Leg pads



Main Body

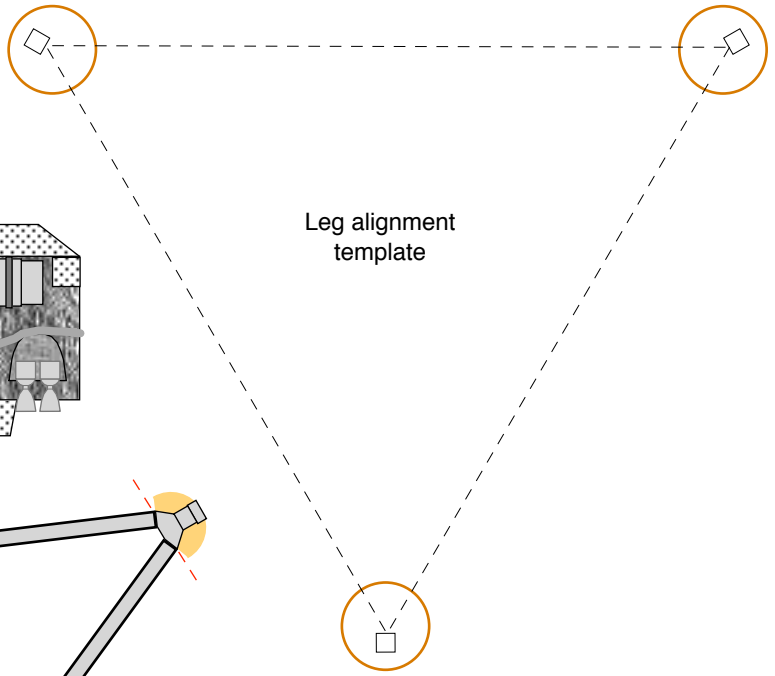

Leg alignment
template

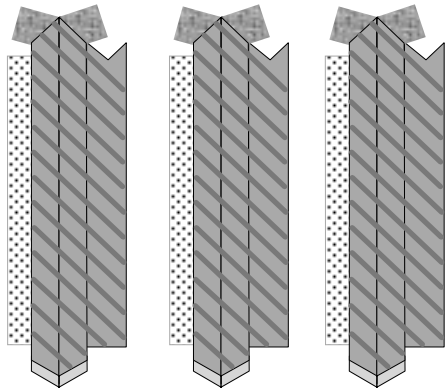

Leg
struts

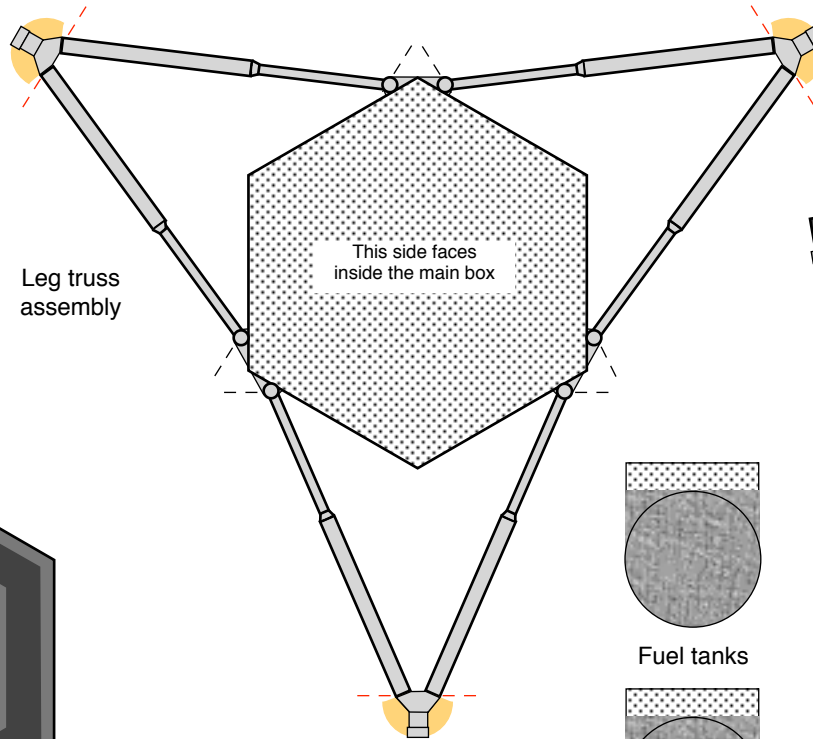

Leg truss
assembly

This side faces
inside the main box

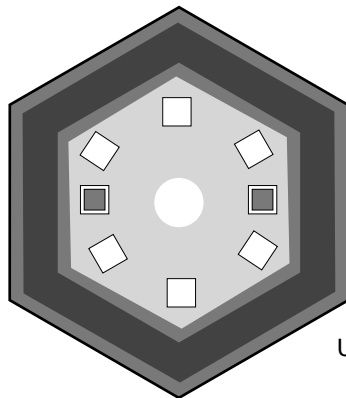

Underside
panel

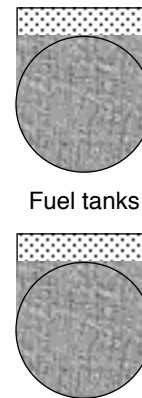

Fuel tanks

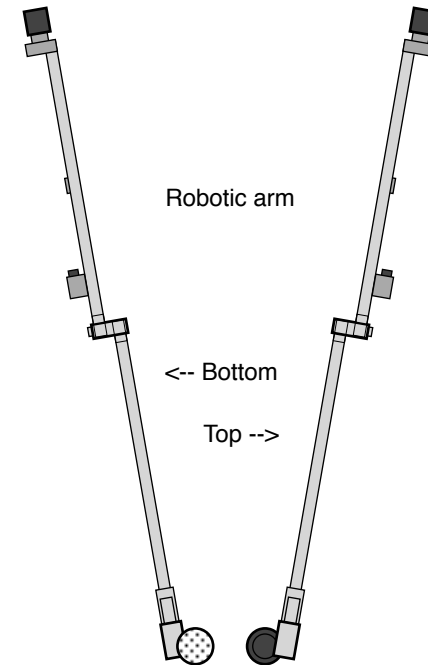

Robotic arm

<-- Bottom

Top -->

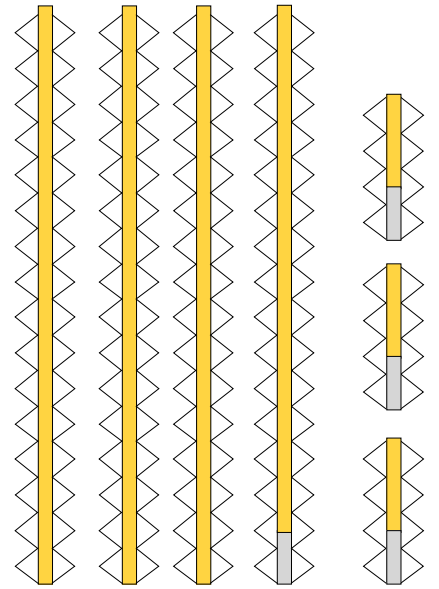
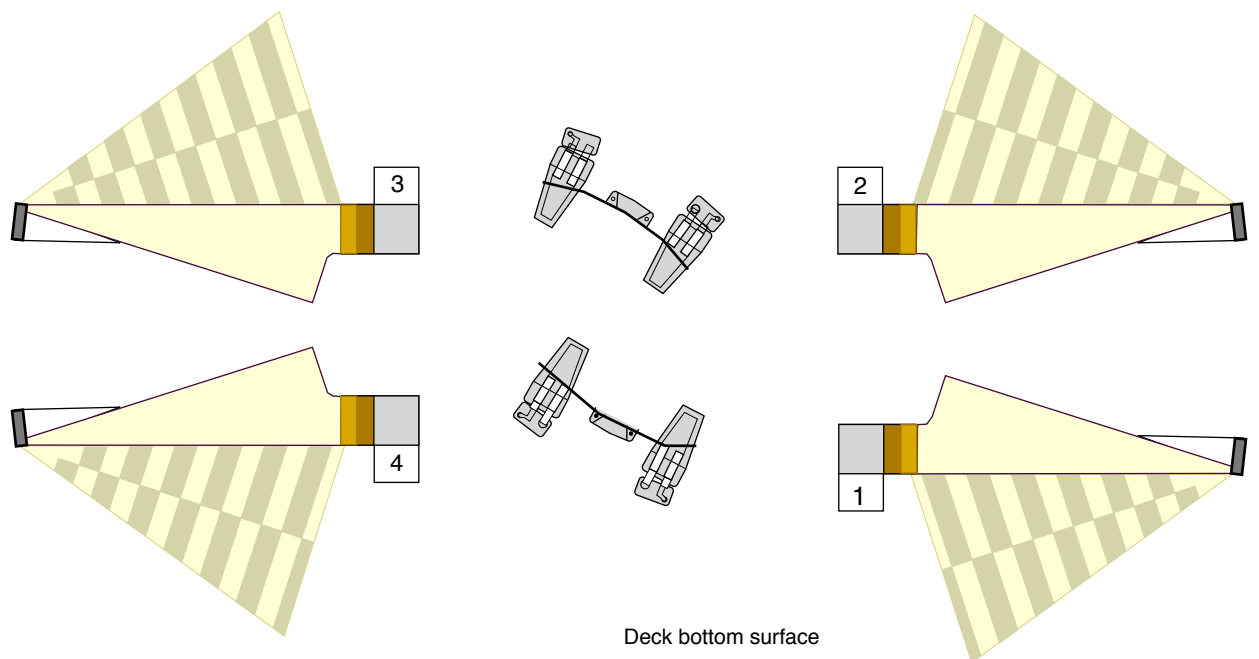

Deck honeycomb edge

Deck bottom surface

Stiffening beams for deck

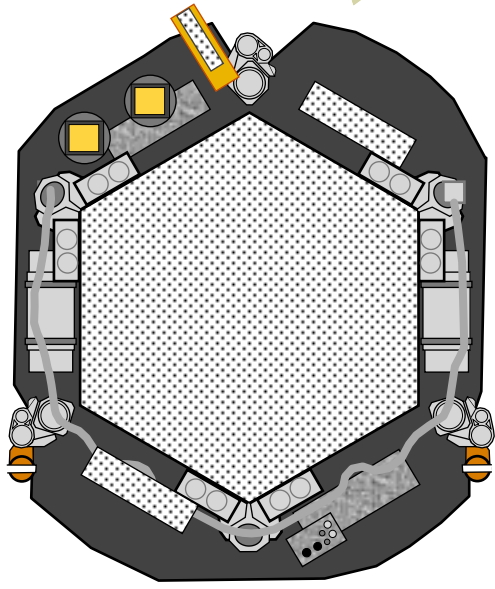
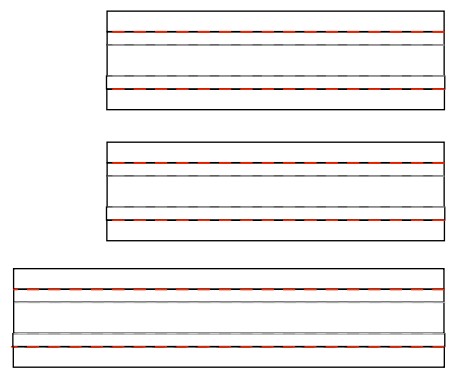

Spare color panels for repairs, mods, etc.

